

The AC Power Line and Audio Equipment

Part 1

Here's a look at the many factors affecting your power line and some tips on how to protect your audio equipment. By Charles Hansen

Audio/video equipment connected to the AC mains can handle more than the 50-60Hz power necessary to operate it. The alternating current at your AC receptacle is laden with power-line harmonics, voltage fluctuations, transients, radio interference, and other disturbances that, in all probability, will reduce your listening pleasure.

THE ELECTRICAL GENERATING STATION

The utilities (or increasingly in these days of deregulation, holding companies) generate our 60Hz AC line power primarily with synchronous AC generators, or more properly, alternators. Electronic power inverters operating from solar power, windmills, or fuel cells may produce a small fraction of the power, often storing it in batteries for peak usage.

Alternators are energy-conversion devices, or *transducers*, that convert mechanical to electrical energy. Transducers of all types operate through the physical laws that relate magnetic and electrical fields to mechanical force and motion:

1. A mechanical force is exerted on a current-carrying conductor in a magnetic field. Conversely, voltage is induced in a conductor moving through a magnetic field.
2. A mechanical force is exerted on a magnetic material that tends to align it with the highest magnetic flux density path. Conversely, moving a permanent magnet or electromagnet past a stationary conductor causes a change in the magnetic flux linking the conductor and will induce a voltage in the conductor.
3. The magnetic properties of a magnetic material are changed when it is mechanically strained. Conversely, magnetic materials are slightly deformed when placed in a magnetic field. This is called *magnetostriction*.
4. When certain crystals are mechanically strained, they form an electric charge. Conversely, when voltages are applied to them, these crystals are deformed in certain defined directions. This is called the *piezoelectric effect*.
5. A mechanical force is exerted on the plates and insulators of a charged capacitor in an electric field. Conversely, relative motion

between capacitor plates and insulators causes a change in the charge or voltage across that capacitor.

APPLICATION OF THE LAWS

You can also see practical applications of these laws in audio transducers: loudspeaker and headphone drivers, relays, microphones, phono cartridges, crystal oscillators, guitar pickups, and magnetic tape heads.

The rotor of an alternator (*Fig. 1*) consists of coils, wound around iron poles, that carry a DC current whose magnitude is controlled by a voltage regulator. This rotor and its windings are called the field, and it produces alternating north and south electromagnetic poles. The DC field current is applied to the rotor in one of two ways: through carbon brushes and slip ring conductors, or by means of rotating rectifiers following a smaller exciter AC generator on the same shaft as the main alternator.

As the rotor turns inside the stator or *armature* of the alternator, the time varying magnetic flux resulting from the rotation of the fixed magnetic field induces current into the stator windings, which are distributed in a number of slots inside the stator iron. A very small field current (maybe 3% of the rated alternator output current) from the regulator controls the much higher stator current.

The frequency of the AC voltage is determined by the number of poles on the rotor and its rotational speed (rpm). A four-pole machine turns at 1,800 rpm to produce 60Hz. (Countries outside North America generate 50 Hz power, while the aircraft industry uses 400Hz power.)

The weight of the alternator for a given output power is directly proportional to the rotating speed of the alternator. Fewer poles require higher rpm, but also result in a lighter machine. However, the rotor must then be designed for the higher centrifugal forces that occur at higher speeds. The field poles are always wound to produce alternate north and south polarity, so only an even number of poles are possible. An alternator must have at least two poles (one north, one south), so 3,600 rpm is the maximum speed for 60Hz.

HARMONICS

It is just not feasible to generate a pure 60Hz sine wave, so cost-effective electric alternators produce a number of low-order 60Hz *harmonics*. These are sinusoidal currents or voltages with frequencies that are integral multiples of the fundamental power-line frequency, and they distort a pure sine wave.

Each of these harmonic sinusoids has a different magnitude from the others. Typically, each harmonic is represented as a percentage of, or dB below, the root mean square (RMS) value of the fundamental. Total harmonic distortion (THD) equals the RMS value of all harmonics divided by the RMS value of the fundamental, usually converted to a percentage.

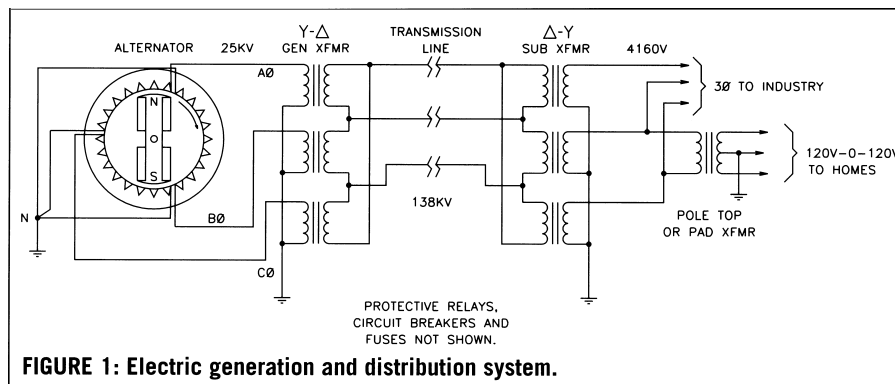

FIGURE 1: Electric generation and distribution system.

Even-order harmonics (second, fourth, and so on) are vanishingly small or nonexistent at the alternator terminals, since a single stator winding circuit produces both the positive and negative AC half-cycles as the alternate magnetic rotor poles pass by.

Alternator designers can take advantage of physics to reduce 60Hz harmonics. In three-phase machines with balanced loads (equal current in all three phases), the *triplens*--the third harmonic and its odd multiples--can easily be cancelled in one of two ways. If power is taken directly from the alternator terminals, the stator winding can be made with a 120° *phase belt*, which fully cancels triplens. Now the winding chord angle, or *pitch*, can be designed to cancel any two other adjacent odd harmonics--the fifth and seventh are usually the highest.

A 60° phase belt results in a slightly smaller machine, but the winding pitch must then be fixed at $\frac{2}{3}$ (0.667) to cancel triplens, and you must accept the higher harmonics as they come. Machines with 60° phase belts are sometimes used in aircraft, where weight is of primary concern.

The curved profile (pole arc) at the face of the rotor pole also has some effect on the higher harmonics, and optimizing the shape of the pole tips that overhang the windings can help reduce higher odd harmonics.

SLOT HARMONICS

An alternator also generates higher harmonics because its stator laminations do not have smooth surfaces. The stator windings reside in slots in the iron that cause flux pulses (called *slot harmonics*) as the rotor passes. By making a slight twist in either the rotor-pole axis or the stator slots, the magnetic axis is skewed by one stator slot-pitch, thus reducing the space harmonics introduced by the winding slots.

Since the utilities must generate huge amounts of power (millions of kilowatts) and transport it over long transmission lines, they do not send power directly from the alternator terminals. Instead, they step the voltage up with large transformers, say from 25kV at the alternator to 138kV or more. This lessens the current in direct proportion, reducing the transmission losses (I^2R).

It is desirable to use a three-phase Y connection in the alternator so its neutral can be grounded--either directly or through a neutral reactor, a device used to limit the unbalanced fault current in a three-phase system. This provides lightning and overload protection. The engineers can then use a wyedelta (Delta-A) transformer (*Fig. 1* again) to remove the third harmonic, since in a current-balanced three-phase delta transformer winding it cancels out.

With the third harmonic cancelled in the transformer, the alternator can use a 60° phase belt, and a winding pitch of $\frac{5}{6}$ (0.833) will cancel the fifth and seventh harmonics. As a result, the 60 Hz sine wave at the step-up transformer secondary has a typical unity-power-factor distortion of 1% to 1.5%, mostly due to non-triplen odd harmonics. You can see this in the spectrum in *Fig. 2*. The third harmonic is not completely cancelled, but it is a low 0.06%.

LOAD-INDUCED ALTERNATOR HARMONIC DISTORTION

Power factor is the ratio of real power (watts) to total volt-amperes (VA). VA is the product of RMS voltage times RMS current. Unity power factor results in the current being in phase with the voltage.

In rotating AC machines, the power factor for any given mechanical load is fixed and continuous. Harmonics are introduced whenever the power factor departs from unity. If the load becomes inductive (motors are the most prominent inductive loads), the phase current lags the voltage. This is called *lagging power factor* (capacitive loads produce a *leading* power factor).

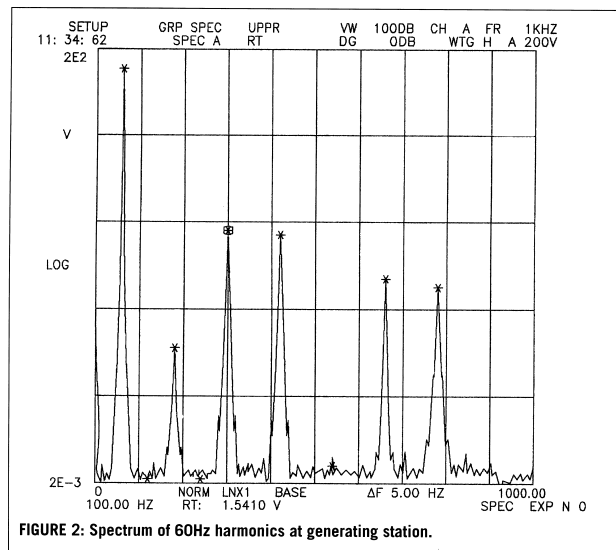

Back at the alternator, the inductive phase current causes the flux between the rotor and stator, which is perpendicular to the rotor pole face with purely resistive loads, to change angle. This alters the relative orientation of the pole and slot flux lines, generating higher order harmonics. The third harmonic is introduced if magnetic loads begin to saturate, as happens when motors or transformers are first energized, or are subject to overload.

All electromagnetic devices (alternators, transformers, motors, and so on) are subject to mechanical forces from the varying magnetic flux. The alternator field is a powerful electromagnet that tries to deflect the stator core iron toward the field poles. Even the slightest relative motion between the windings or their iron cores, as well as vibration in the structure, will produce harmonics.

Under normal conditions, the force acting on the windings is much smaller than that acting on the iron core. However, if a short circuit should occur in a large alternator or transformer, the force on the coils could be extreme. I once saw the neutral-reactor coil in a 32MW gas turbine generator completely straighten itself out when a short occurred in the main generator step-up transformer. Protective relays saved the generator, turbine, and switchgear, but the neutral reactor and transformer were scrap!

High-voltage three-phase power is sent over transmission lines and through substations, whose Delta-Y transformers step the voltage back down to intermediate levels, and then on to industry and homes (see *Fig. 1* again). Industry often makes direct use of three phase voltages between 440 and 4160V but homes require single-phase 120V-0-120V (the "220V" service entrance line into your home).

This is provided by pole-top or pad step-down transformers, and along the way the balanced three-phase loading is locally upset, and some third harmonic is introduced. The 120V-0-120V AC line is not balanced, so differences in loading on each side of neutral can introduce even harmonics into the 60Hz waveform. As a result, the typical 60Hz AC line distortion at your home will increase to 3% to 3.5%.

POWER QUALITY PROBLEMS

The conveniences of modern society employ a large variety of nonlinear loads, where the load current is not proportional to the instantaneous line voltage. Examples are motor controllers, switching power supplies, and rectifier filters. The filter capacitors in a rectified linear DC supply may draw current only at the peaks of the AC line voltage. Here, the instantaneous power factor varies over each half cycle of the 60Hz AC line.

These loads cause adverse effects on the line voltage that can, in turn, damage capacitors, relays, motors, and transformers exposed to the harmonic distortion. The harmonics can also cause excessive neutral currents and higher reactive currents that impose power-factor penalties, thus limiting the total output from utility alternators.

Current distortion interacts with the wiring impedance, producing voltage distortion that can interfere with the operation of other equipment. Conducted noise can enter your electrical system through the utility ground. If the ground wire contains noise or harmonics, they will travel the path of least resistance and can return to their point of origin through equipment plugged into your receptacles.

Motors are sensitive to voltage distortion. High frequency harmonic currents cause higher operating temperatures in the windings due to eddy-current losses. Harmonic voltages can produce excessive vibration, leading to abnormal bearing wear and reduced reliability. Harmonic currents in transformer windings generate excessive heat even if the transformer is not carrying its full-rated electrical load.

The normal steady-state voltage range at the “pole top” is 112 to 123V AC (224 to 246 for a nominal “220V” line). It can be much worse in remote rural areas. Most consumer electronic equipment is designed to operate between 110 to 125V AC. Power quality problems can manifest themselves in a number of ways².

STEADY-STATE PROBLEMS

A power failure or outage is a zero-voltage condition lasting for more than one cycle ($\frac{1}{60}$ second), while a blackout is a total power failure lasting from seconds to hours or more. A brownout is a region-wide reduction in the steady-state voltage imposed by the utility in response to high electrical consumption, such as peak air-conditioner demands in the summer. If things become really bad, utilities may be forced to use rolling blackouts to further protect the power grid from excess demand or insufficient power generation reserve.

TRANSIENT PROBLEMS

All power-line disturbances are transient by definition. A *sag* is a cycle-to-cycle decrease in the line voltage below 105V AC for 0.5 seconds (30 cycles of the 60Hz line frequency) or more, which then returns to the normal level. A *dip* is a fast sag.

A *surge* is a cycle-to-cycle increase in the line voltage above 127V AC for 0.5 seconds or more, which then returns to the normal level. If the voltage fails to return to normal, overvoltage protection relays open the alternator or distribution circuit breakers to protect the customers.

An *impulse* is a short-term (sub-cycle) disturbance superimposed on the AC sine wave that typically lasts between 0.5 and 100 microseconds. In-phase impulses ranging from 400V to 5600V (the latter from lightning strikes) that increase the instantaneous line voltage are called spikes. *Spikes* in excess of 600V are potentially very damaging, since this is the insulation voltage that residential electrical wiring and fixtures are generally designed to withstand.

Out-of-phase impulses that decrease the instantaneous voltage are called *notches*. These typically last as long as spikes but can be up to several milliseconds. Spikes and notches usually come in pairs, or in an oscillating series, due to power-line reactances.

Voltage flicker occurs when you start large motors, or during heavy load changes on a utility distribution system. This flicker is objectionable only if the magnitude of the voltage drop and the frequency of occurrence exceed the threshold of perception documented on the IEC 61000-4-15 voltage-flicker curve.

LIGHTNING

Lightning is one of the leading causes of power outages and transients on utility power lines. The surge currents associated with lightning strikes interact with the distribution-system impedance, producing large voltage transients that are transmitted to remote parts of the grid. Lightning can cause transients on power lines without even hitting them. The large electric fields (up to 70V per meter) during a cloud-to-cloud discharge can couple into the system, producing substantial induced voltage transients.

Normal utility operations, such as load switching, the operation of disconnects on energized lines, adding or removing power-factor-correction capacitor banks, and the automatic operation of line reclosers and transformer tap changers, can all cause transients.

HARMONIC CURRENTS

IEEE Standard 519-1992 sets the US limits for harmonic current distortion, or *total demand distortion* (TDD). European Union (EU) Standard EN61000-3-2 is similar, and must be met before a device can gain the CE Mark required for sale in the European market.

These standards limit the harmonic content of current imposed back into the AC line by any device or its power supply drawing more than 75W. (This was supposed to change to 50W, but the notice has been cancelled.)

The increased use of switching power supplies can generate considerable noise or current harmonics back into the power line, thus contributing greatly to this problem. The maximum TDD varies with the ratio of utility short-circuit current (I_{SC}) available at the particular location in the distribution system to the maximum load current drawn by the user’s equipment (I_L), and by the type of device. This ratio, I_{SC}/I_L is called the short-circuit ratio (SCR)³.

If the SCR is 20 or less, the device cannot impose more than 5% TDD on the AC line, with a maximum of 4% for any single harmonic below the eleventh. Even-order harmonics are limited to 25% of the adjacent odd-harmonic limits. The harmonic range covered by the regulations extends to the 39th (2340Hz for the 60Hz power line).

Things may not be as stringent in your neighborhood, depending on how many homes the pad or pole-top transformer is designed to serve, and your proximity to industrial loads. If the SCR is 1000 or more, the allowable 519-1992 TDD is 20%, with a maximum of 15% for any single harmonic below the eleventh. Pity the poor audiophile living near that location!

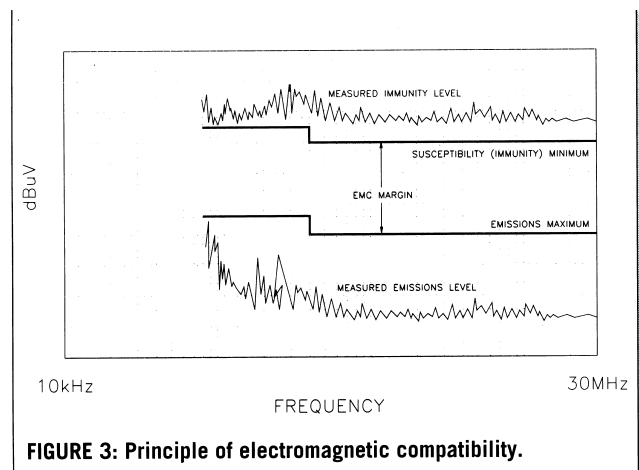

FIGURE 3: Principle of electromagnetic compatibility.

The AC Power Line and Audio Equipment

Part 2

This audio veteran examines the causes of interference and offers tips to ensure a clean AC power line.

By Charles Hansen

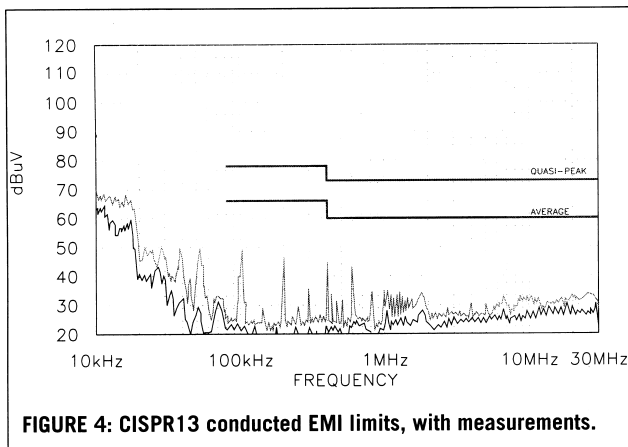

FIGURE 4: CISPR13 conducted EMI limits, with measurements.

All non-incandescent lighting systems can cause harmonic current distortion. Fluorescent and high intensity discharge (HID) lighting systems can produce from 10% to more than 40% THD, depending on the design. Home lighting electronic-ballast operating frequencies extend well into the RF range, but they must meet the stringent interference limits of EN55015/CISPR15 (more on these limits later).

Three-phase variable speed drive controllers cause a type of voltage distortion called *line notching*, which produces additional zero crossings on the voltage waveform. In the 1970s I worked for a company that installed four 150HP thyristor-controlled drive motors. The notching was so bad that even the clocks failed to keep proper time, and correcting the power quality problems required some serious power line filtering.

Incidentally, if you hear excessive 60Hz or 120Hz hum in your audio equipment, it is probably not due to injected harmonics, but to equipment power-supply problems.

Part 2 takes a look at electromagnetic interference and how to test for it.

References

1. M.G. Say, Wiley & Sons, *Alternating Current Machines*, 5th Ed.
2. IEEE C62.41-1980, *Guide for Surge Voltages in Low-Voltage AC Power Circuits*, January 30, 1981 (ANSI Standard)
3. For those familiar with alternator design, this is not to be confused with generator SCR, which is the ratio of field current at no-load rated voltage, to the field current required to develop rated stator current into a short circuit.

Reprinted, with permission, from audioXpress, Issue 9, 2001, p.p. 16-19 of audioXpress magazine. © Copyright 2001 by Audio Amateur Corporation. P.O. Box 876, Peterborough, NH 03458, USA. All rights reserved.

Electromagnetic interference (EMI) is any undesirable electromagnetic emission or any electrical or electronic disturbance, man-made or natural, which causes an undesirable response, malfunction, or degradation in the performance of electrical equipment. EMI is broad-spectrum interference, either conducted on the power line, or radiated by wiring or circuits to susceptible equipment.

A utility alternator always produces some level of EMI. It is produced primarily by brush arcing in slip-ring alternators, or by rotating rectifier spikes in brushless alternators. The voltage regulator produces additional interference, which is normally a pulse-width modulation (PWM) switching regulator.

Radio-frequency interference (RFI) is any undesirable electromagnetic interference within the frequency spectrum assigned to radio transmission.

Conducted interference is noise injected by a device back into AC mains supply. It is distinguished from powerline harmonic distortion by its higher frequency range.

Radiated EMI comprises E-Field (electric) and H-Field (magnetic) components. Electric fields exist in space between two potentials, while magnetic fields exist around a current traveling through space or a conductor. You can easily control electric fields with ground shielding. Magnetic fields can penetrate ordinary conductors and require high-permeability magnetic materials to contain them.

The most common EMI radiator is the AC power cord of an electronic device. The power cord or internal wiring may propagate any conducted interference generated by the device, especially if the conductor length is close to one-fourth the wavelength of the interference frequency.

EMI SOURCES

The rectifier diodes in power supplies produce spikes and ringing on the AC line as they abruptly turn off and on. The magnitude of the spikes depends on the diode recovery characteristics. Fast-recovery and fast/soft-recovery diodes are available to minimize RFI^{4,5} produced by diode switching. Capacitor or RC snubbers across the diodes can further reduce RFI⁶.

Switching power-supply semiconductors and their energy storage inductors and transformers can produce transients with lots of RF energy.

Light dimmers and motor speed controls operate by conducting for only a portion of the 60Hz AC cycle. When the SCR or Triac in the control is gated on, its fast turn-on pulse produces harmonics well into the RF spectrum.

RF signals are also intentionally placed on the AC line. X-10TM controllers place their digital codes on the AC line during the zero-crossing of each AC half cycle (120 times per second for a 60Hz power line). Also, power-line-carrier coupling system RF signals are used to control remote unmanned power substation circuit breakers, providing a means for detecting faults on transmission

lines. Power-line computer networking currently moves data along 120V wiring at 350kbps (kilobits per second), and promise speeds up to 11Mbps⁷ (megabits per second). In the future, “smart” appliances may add their data to the power line.

INTERNATIONAL EMI LIMITS

EMI must be regulated in order to allow equipment to function properly without suffering degradation in performance due to interference generated by the equipment itself, or by other electronic devices. EMI regulations are designed to prevent real-world problems by providing a sufficient electromagnetic compatibility (EMC) margin between the worst-case emission and susceptibility limits (Fig. 3). The specifications change periodically, so the information presented here is a snapshot of what I believe to be the limits at the time of this writing.

Conducted EMI can be in the form of voltage or current. Power-line-conducted emissions are evaluated from 150kHz to 30MHz using an RF current probe or a line-impedance stabilization network (LISN) connected in series with the power lines to the equipment. The LISN establishes a consistent 50-ohm impedance that allows for repeatability of test results. The conducted emissions are connected to measurement equipment through an RF connection port on the LISN. Some applications are capable of performing magnetic-field measurements down to 10kHz using H-field probes.

Radiated EMI is assumed to occur in the upper frequencies, from 30MHz to 10GHz. It is measured with a variety of broadband antennas at a standard distance (3-30m) from the equipment under test (EUT).

Radiated emissions are measured in dB above 1 microvolt per meter (dB microvolt). Conducted emissions are measured in dB above 1 microamp (dBmicroamp), but commercial test data is presented in dBmicrovolt, measured across the standardized 50-ohm measurement impedance. (Aerospace conducted emissions data is presented in dBmicroamp.)

EMI emission limits are also placed on *unintentional emitters* in order to protect the radio communications spectrum. An unintentional emitter is a product that intentionally generates RF for use within the device, or that sends RF signals to associated equipment via shielded interconnecting wiring, but which is not intended to emit external RF energy by radiation or induction. Examples of unintentional emitters are TV and radio receivers, CD and DVD players, computers, set-top cable boxes, cable selector switches, and so on.

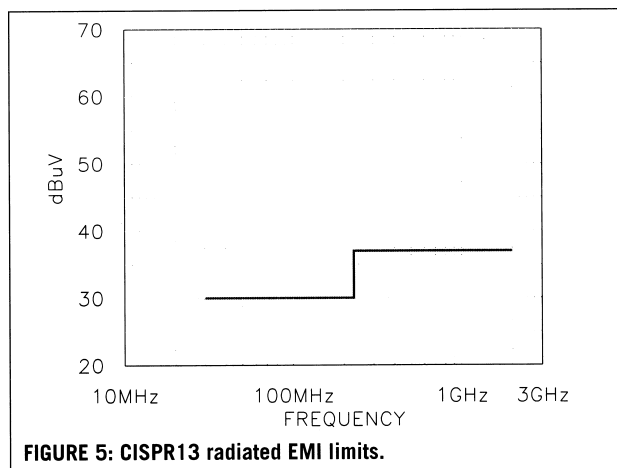

FIGURE 5: CISPR13 radiated EMI limits.

THE CE MARK

The CE Mark is mandatory for products marketed in the European Union. All manufacturers are responsible to see that their products conform with the appropriate safety, electrical, EMC and RFI emission, and immunity requirements for the EU common CE label.

Most equipment manufacturers tend to design to the worst-case conditions of all established standards, to reach the broadest possible market.

EU standard European Norms EN55013 (CISPR13) sets forth the limits for and methods of measurement of the interference characteristics of sound broadcast receivers, television receivers, and associated equipment. It also covers cable and satellite receiving equipment. Associated equipment is either intended to be connected directly to AM, FM, or TV receivers, or to generate or reproduce audio or visual information (audio amplifiers, active loudspeaker units, turntables, CD and DVD players, magnetic recording and playback systems, and electronic musical instruments).

The conducted and radiated emissions limits for CISPR13 are shown in Figs. 4 and 5, respectively. Figure 4 also shows an example of the conducted interference measured with a resistive load (lower curve), and that of a typical switching power supply. Information technology equipment such as personal computers are governed by a different standard (EN55022/CISPR22), even if they are intended to be connected to a TV broadcast receiver.

The EU and US Federal Communications Commission (FCC) limits for conducted and radiated emissions are based upon the end application of the device. Units intended for residential use must comply with the more stringent Class B limits, which are 10dB tighter than the industrial/commercial Class A limits.

Military limits (MIL-STD-461 and -462) are even tougher (almost 30dB tighter than industrial/commercial), cover a wider range of frequencies, and include more stringent immunity limits. Commercial aircraft use a similar EMI specification, called DO-160. These aerospace-radiated interference tests are measured 1m from the EUT, while the FCC and EU tests are performed with the antenna 3-30m from the EUT.

EMI IMMUNITY

In addition to the emissions limits, requirements exist that restrict the degree to which equipment can be adversely influenced by radiated and conducted noise. These specify the EMI levels that products must tolerate without misoperation. This is called *immunity*, or *susceptibility*. The degree to which power-line harmonics and EMI are audible in audio equipment, and even the definition of this misbehavior, is the subject of much debate, typically split along

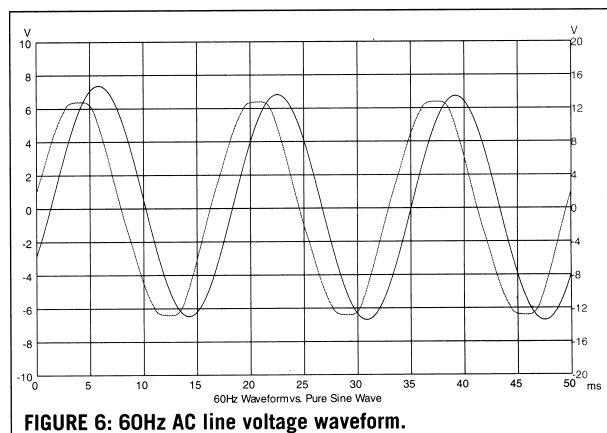

FIGURE 6: 60Hz AC line voltage waveform.

the subjective/objective dividing line. However, there is no question that the power supply in a piece of audio equipment is part of the audio signal path.

The EU immunity limits for audio and TV receivers and associated equipment are governed by EN55020/ CISPR20. Conforming equipment may be required to show immunity to RF field strengths up to 2V per meter. In the US, the FCC specifies emission standards, but tends to be more hands off toward immunity unless public safety is involved. This will undoubtedly change, what with the many IEEE committees at work to align the various worldwide standards.

A radiated immunity test is designed to verify the immunity of equipment to electromagnetic fields generated by radio transmitters, transceivers, cellular phones, and various industrial electromagnetic sources. You cannot logically expect any radio receiver to be immune to the very signals it is expected to receive, so EN55020 requires broadcast receivers to demonstrate test immunity up to 150MHz. RF immunity tests for associated equipment may extend up to 1000MHz (1GHz).

The *Immunity to Conducted Electrical Transients* test is designed to verify immunity to bursts of short-duration, fast-rise-time transients that may be generated by the switching of inductive loads or electrical-system contactors. The transients are applied directly to the power mains, and capacitively coupled to signal lines. Many manufacturers also include surge-suppression devices in their designs.

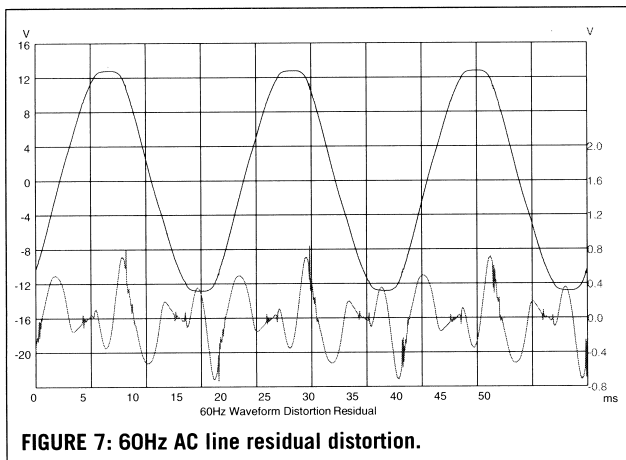

FIGURE 7: 60Hz AC line residual distortion.

AC-LINE HARMONIC TEST DATA

EMI testing requires specialized equipment and certified test facilities. Since manufacturers do an excellent job of keeping RF energy out of their equipment, I have limited my testing to 60Hz AC line harmonic measurements.

Figure 6 shows the 60Hz AC-line-voltage waveform (left trace) compared with the pure 60Hz sine wave from my distortion test set. I adjusted both waveforms in amplitude so their RMS values at the scope inputs are equal. You can see how harmonics have flattened the top of the AC-line-voltage waveform. The third, seventh, and eleventh harmonics flatten the peak of the fundamental 60Hz. The fifth, ninth, and thirteenth harmonics add to the peak, but not enough to offset the large effect of the third.

The distortion residual waveform for the AC-line voltage is shown in Fig. 7. The upper waveform is the AC voltage, and the lower one is the monitor output (after the THD test set notch filter) (not to scale). This distortion residual signal shows a series of odd 60Hz harmonics, with additional noise. The THD on this particular Sun-

day morning is 3.15%. During the week, the THD usually increases to about 3.5% as industry goes to work.

The spectrum of the 60Hz line voltage is shown in Fig. 8, from zero to 2.6kHz. The second, third, fourth, and fifth harmonics relative to the 60Hz fundamental measure -70dB, -33dB, -75dB, and -33dB, respectively.

Next, I'll investigate the line currents in a typical full-wave rectified capacitor input DC power supply. The test setup I used looks at the DC voltage across a 2A DC load, and the AC current at the secondary of the power-supply step-down transformer. This particular 12A supply has about 60,000microF of filter capacitors, and is used to power car stereos and other 12V DC devices for bench testing.

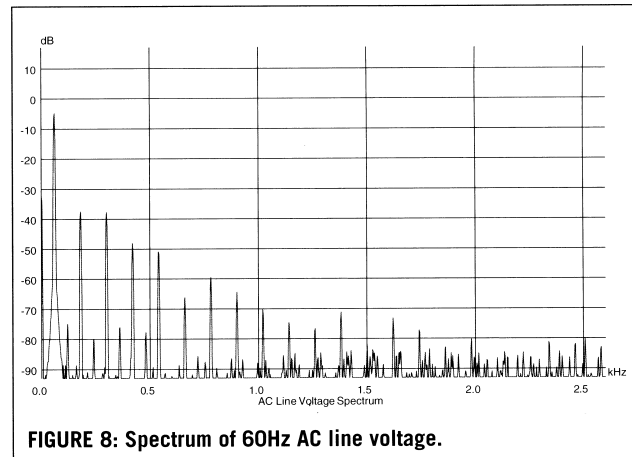

FIGURE 8: Spectrum of 60Hz AC line voltage.

HIGH INRUSH CURRENT

Figure 9 shows the DC voltage and transformer secondary AC current when the power supply is first energized into the 2A DC load. I used a current transformer with a response range of 25Hz to 5kHz to measure the AC current. The AC inrush current is very high for the first few cycles while the filter capacitors charge, then it decreases exponentially.

Figure 10 shows the steady-state condition, with the capacitors fully charged and supplying the 2A load. The 4A AC current peaks into the full-wave rectifier are not continuous over each AC cycle. The diodes conduct only when the voltage across the filter capacitor falls below the instantaneous transformer-secondary voltage, in a series of opposite-polarity pulses spaced 8.33ms apart. The height and width of these pulses increase in proportion to the load being supplied.

In Fig. 11, I used AC coupling on the DC-voltage input (top trace) to view the AC ripple on the DC voltage. The bottom trace is still the steady-state AC line current. You can see where diode conduction begins at each valley in the ripple voltage.

Compare the AC-current spectrum in Fig. 12 with the AC line voltage spectrum in Fig. 8. While the line-voltage THD is 3.15%, the transformer-secondary AC-current THD is a whopping 72%. The second harmonic is very prominent at -41dB below the fundamental 60Hz, with the third almost as high (-2dB) as the fundamental. The fourth and fifth measure -47dB and -13dB, respectively. There is a lot more noise and hash in the spectrum as well. These high harmonic currents are impressed back through the power transformer onto the AC line, where they can adversely affect other connected equipment.

FILTERS AND FIXES

A dedicated line from your service panel to your audio equipment (I call it “star sourcing,” similar to star grounding) can do wonders to keep noise and harmonic currents out of your audio equipment. With a dedicated supply, your amplification need only endure the noise from its system mates, rather than the hash from the washer, garage door opener, and furnace.

My own electrical supply consists of a dedicated 20A line from a dedicated circuit breaker, to a single heavy-duty outlet pair near my audio setup. I made an outlet extender from a four-gang steel electrical box, a heavy-duty Hubbell three-prong plug and a short length of ten-gauge three-conductor power cord. The extender box contains three 20A Hubbell hospital-grade (orange) duplex outlets, star-wired from a 20A switch using 12-gauge copper wire. The integral switch allows me to operate all the audio components at once. The extender-box plug allows me to disconnect the audio system completely in case of a thunderstorm, protecting it from lightning-induced surges.

If your outlets have spring clip “push-in” connections, do not use them. Terminal screws provide more surface area and a higher compressive force, for minimum resistance. I connected an individual green ground conductor to each outlet ground screw, then connected the first outlet ground to the metal box as the required safety ground. It was not easy to find a conventional four-outlet cover plate for the box. I found four-gang Decora™ plates, but none for four traditional receptacles. My solution was to make a functional cover by cutting one edge of two double outlet cover plates so they fit tightly over the steel box.

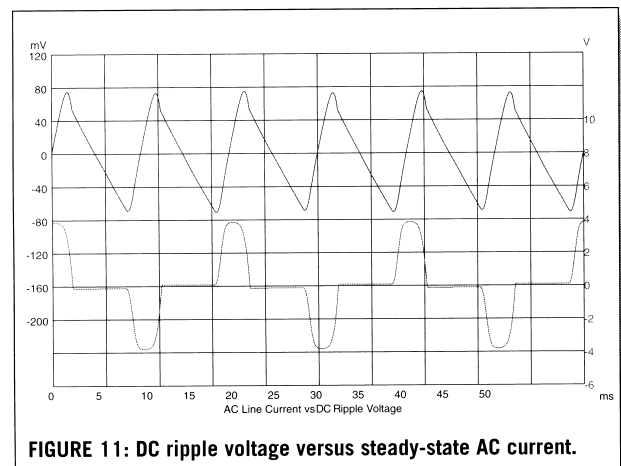
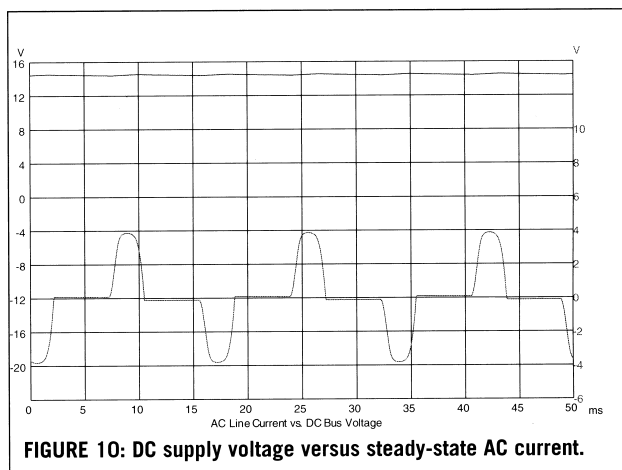
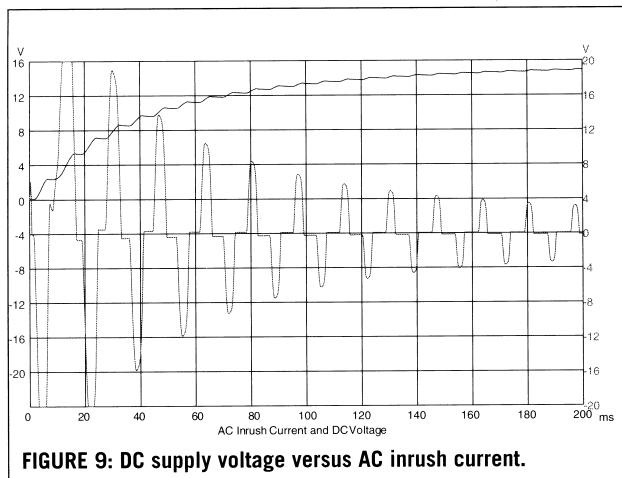

CONNECTION ORDER

I plug my main and subwoofer amplifiers into the outlet closest to the line cord switch. Next come my rear channel amplifier and preamp. The CD player and cassette deck go into the third outlet. With all six outlets taken, I had to plug my turntable into a switched outlet on my preamp. The idea is to have the equipment with the highest current draw closest to the line-cord side of the box.

Some components have a detachable three-conductor IEC cable/receptacle, while others have an integral two-conductor power cord. In the latter case, if the plug is not polarized, you can experiment with the plug polarity to determine which orientation produces the lowest hum. Work your way back from the power amplifier, selecting the orientation that results in the lowest hum and noise. Do this without your interconnects plugged in, because you are first trying to eliminate the hum caused by AC-line ground loops.

Do not defeat polarized plugs or three-conductor line cords with a ground-lifting “cheater” plug. If you do this and a fault occurs, the chassis of your equipment could end up at 120V line potential, and your audio interconnects could be forced to carry huge 60Hz fault currents. At worst, it could cause a fire and damage some of your audio components. At best, the fault current on the shields of unbalanced interconnects will induce a high level of 60Hz hum into preamp or amplifier inputs, resulting in damage to your speakers, not to mention your hearing.

Once you have optimized the AC power, you should repeat the process with each interconnect in place in turn, starting from the power amplifier and working back to each audio source. Finally, find the quietest connection for your turntable grounding wire.

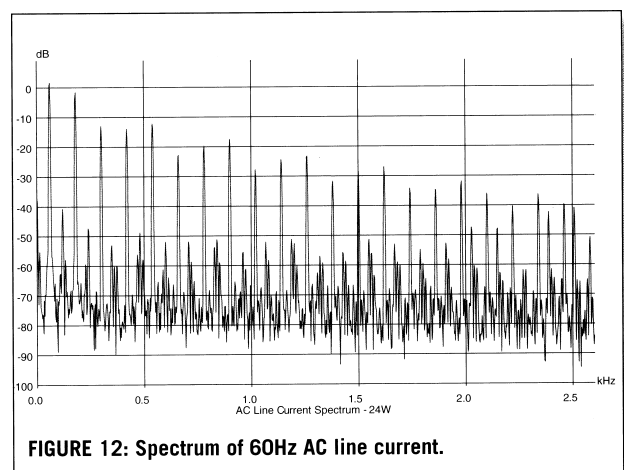

CROSS-COUPLING PREVENTION

In order to prevent cross-coupling of hum and noise between your components, make sure that the signal interconnects, the speaker cables, and the power cords are all kept away from each other. Power cords, speaker cables, and interconnects should only cross at right angles, to minimize pickup. I have seen articles suggesting that interconnects and cables should not even lie on the floor, so you can try some of those recommendations as well. Many audio racks have wiring channels that provide wire separation and also make for a neat installation.

There are many power conditioners and local filters available for audio systems⁸ some of them quite expensive. Their purpose is to reduce the emission of EMI (suppression) and to prevent EMI from entering the electronics (noise immunity). The proper selection of an EMI filter encompasses mechanical packaging, leakage current, insertion loss, rated voltage and current, conformity testing, and compliance approvals. As I mentioned earlier, manufacturers are responsible for the conformity of their products to all relevant EMC specifications.

Power conditioners or power-line filters may offer further sonic improvements, but they may also insert additional series impedance in your AC supply lines that adversely interacts with filtering designed into your equipment in the first place. In any event, your first step should be to make sure the AC power to your audio setup is as good as possible.

References

4. W.Jung, "Measured RFI Differences Between Rectifier Diodes in Simple Capacitor-Input Power Supplies" TAA 1/94, pp. 26-27.
5. D. Metzger, "Diode Protection – Another Aspect" QST 10/97, p. 38.
6. J. Hageman, "Calculating Optimum Snubbers" AE 1/98, pp. 26-31.
7. Homeplug Power Alliance, www.homeplug.org.
8. "High End Survivor" Stereophile, May 2000, pp 50-59.

Reprinted, with permission, from audioXpress, Issue 10, 2001, p.p. 66-73 of audioXpress magazine. © Copyright 2001 by Audio Amateur Corporation. P.O. Box 876, Peterborough, NH 03458, USA. All rights reserved.

The logo for SMART consists of the word "SMART" in a bold, stylized, outlined font. The letters are interconnected, with the 'S' and 'M' sharing a vertical stroke, and the 'A', 'R', and 'T' also sharing vertical strokes. The 'I' is a simple vertical bar. The overall appearance is that of a thick, hollow outline.

5945 Peachtree Corners East
Norcross, Georgia 30071
(800) 45-SMART or (770) 449-6698
email: sales@smartdev.com
Website: www.smart-cinema.com